

Six Ported 4-Way

This circuit controls two double acting cylinders with a single 4-way (6 ported) valve. When V-1 has been depressed, actuation of V-3 will extend or retract C-1. When V-2 has been depressed, actuation of V-3 will extend or retract C-2.

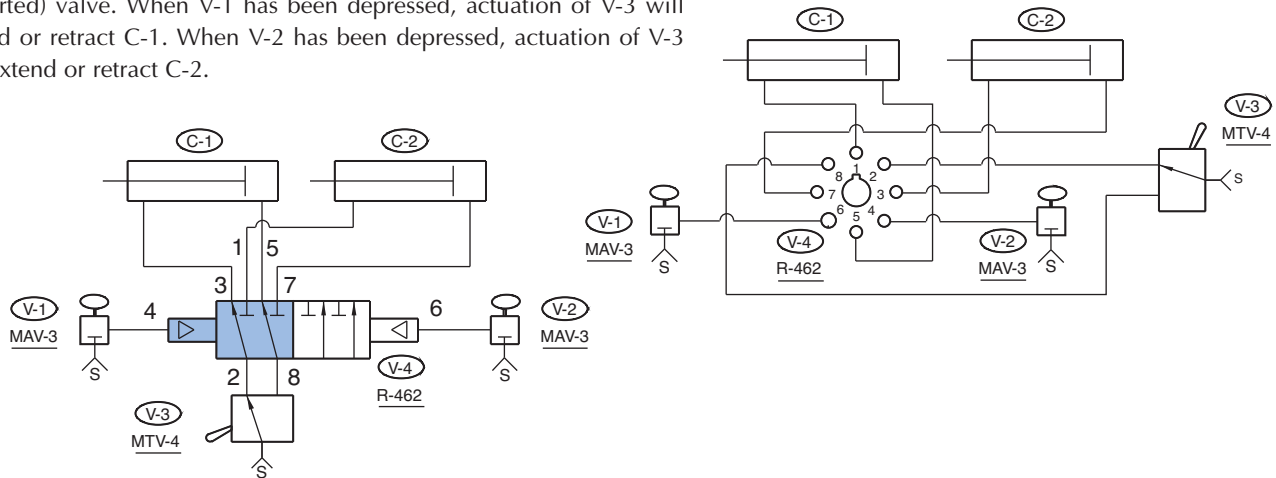

Three Input "And"

The R-353 valve will give an output at C-1 only when V-1, V-2, and V-3 are depressed. Remove any of the three inputs and the output ceases.

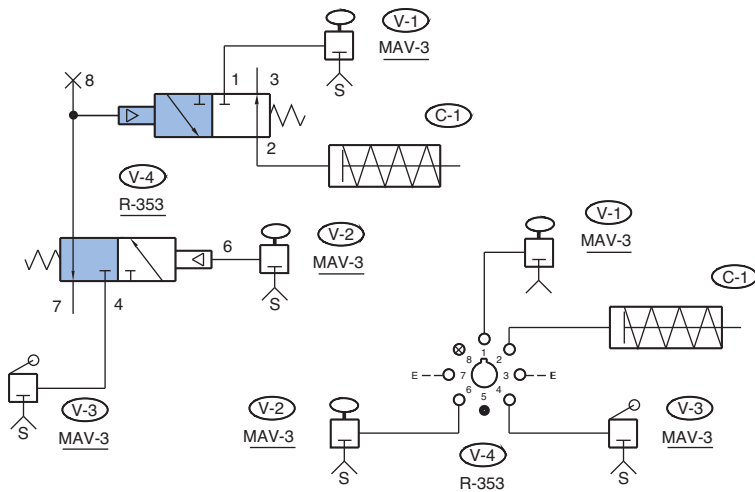

Exhaust Piloted 3-Way Valve

Pressure in line 7 holds pilot down on the valve V-2 which has no output signal. When V-1 is actuated, pressure is exhausted from line 7 faster than the adjusted supply can make it up. The spring then shifts the valve giving an output at ports 2 & 8. (Port 8 is shown as blocked.)

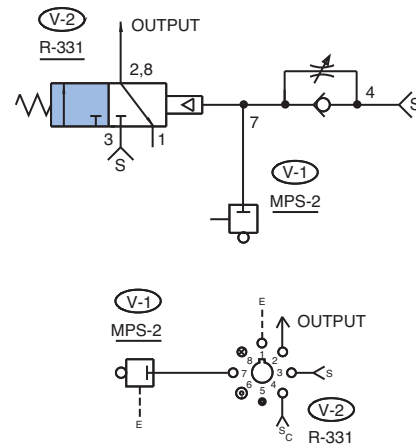

Piloting From Two Inputs

Actuating of either V-1 or V-2 will pilot V-3 causing C-1 to extend. The R-321 is shown Normally-Closed. It may also be used Normally-Open, as a selector, or as a diverter. An R-315 provides the same function by having two separate pilots.

